

2859336 - Cable clamp KSF317

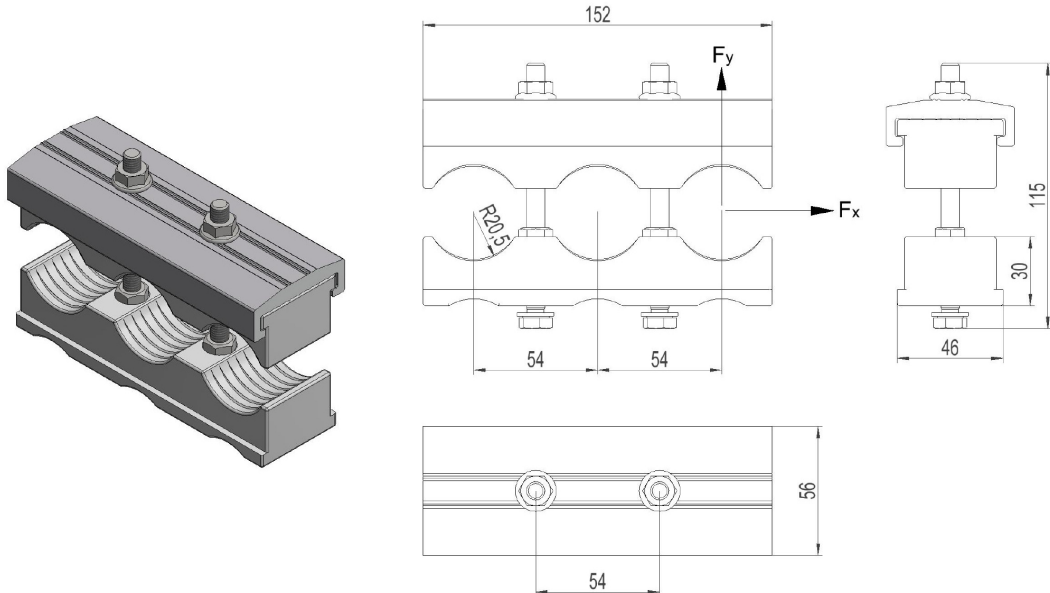

Description	Cable clamp 3-cables Ø17-42mm. Reinforced version. Delievered with fasteners.
Unit	PSC
Weight	0,45 kg
Material	Polyethylene
Material-2	Aluminium, anodised-brown
Number of cables	3pcs
Suitable for cable diameter	Ø17-42mm
Breaking load (static)	Fy=15kN / Fx=6kN